

The RDR Remote Inclinator Package is a complete remote angle monitoring and early warning system.



Features

- Single or Dual Axis Measurement
- Custom Input Ranges from $\pm 4^\circ$ to $\pm 100^\circ$
- LCD Displays Angle in Degrees, Percent Grade, or Inch per Foot Rise
- 0.1° or 0.01° Display Resolution
- Relative Zero Function
- Minimum/Maximum Display
- Analog 0 to 5VDC Output
- RS232 Serial Output
- Up to 4 Open Collector Switch Outputs
- Optional Adjustable Trip Angle Settings
- High Current-Sink Capability
- Lamp/Solenoid/Relay Driver

Applications

- Slope Warning System
- Roll Over Early Warning
- Platform Leveling
- Pitch and Roll Monitoring
- Vehicle Tilt Monitoring
- Antenna Positioning
- Boom Angle Indicating
- Safe Curve Speed Indicating (Ball Banking)
- Sound System Remote Speaker Alignment
- Mining/Boring Equipment Leveling
- Bang-Bang Type Valve Controller

Description

The RDR Remote Inclinator Package is an extension of the RDI series. The package is supplied as a calibrated set featuring an environmentally sealed inclinometer box (single or dual axis), an LCD display box, and the interconnecting cable (maximum 200 feet).

The RDR has the same features as the RDI including user defined inclination ranges, multiple outputs combinations, and adjustable switch output trip angle settings.

This is a semi-custom unit where all subassemblies are stock but specific functions are customized. A modular design allows the customer to select the measurement range, output type, and temperature compensation that best suits the individual application. Standard input ranges $\pm 10^\circ$, $\pm 30^\circ$ and $\pm 70^\circ$ are available for both single and dual axis models - these can be scaled to specific ranges (ie: $\pm 45^\circ$) per axis. Special single axis ranges up to $\pm 100^\circ$ are available. Non-symmetrical (or scalable) ranges (ie: -10° to $+90^\circ$) are available for applications that only tilt in one direction.

The LCD display can be configured to display degrees, percent grade, or inch per foot rise with either 0.1 or 0.01 degree resolution. The display models come standard with 3 built in LED's (1 green, 1 yellow, and 1 red). These can be set activate at predefined angles within the specified measurement range - providing the operator a bright visual warning signal.

Examples of LED programming: For leveling applications - the LED function is set so the green LED turns on when level then switches to yellow or red when out of level; For indication of safe and unsafe conditions (such as preventing vehicle rollover) - the green light would indicate the vehicle is within the safe operating zone, the yellow light would indicate a warning zone, and the



RIEKER
INCORPORATED

RDI Series: **RDR**

Digital Remote Inclinometer Package

red light would indicate the vehicle is on a slope that exceeds the recommended safe operating zone - giving the operator a bright visual immediate danger signal to return to more even ground.

The LCD display model also provides a Relative Zero and a Minimum/Maximum Angle function. The Relative Zero (REL) allows the operator to temporarily zero the digital readout to obtain relative slope changes. The operator will always know when the device is in the REL mode by the (*) symbol that is displayed after the angle. The Minimum/Maximum Angle (MIN/MAX) function provides the smallest and largest angle the device has sensed since the last reset.

The RDI can be supplied with multiple output configurations: Digital LCD Display, Analog Voltage 0.25 to 4.25V output, Digital Serial RS232 output, and up to 4 Open Collector Switch Outputs providing maximum functionality.

Optional Temperature Compensation can be added to provide increased accuracy. For applications that require remote angle measurement (the sensor unit is mounted separately from the Display box) we offer Remote Inclinometer packages and Remote Angle Displays with multiple sensor options.

The analog voltage (0-5V) output is available as either temperature compensated or non-temperature compensated depending on the required accuracy for the specific application (operating temperature is used to determine this option). A 12 bit digital to analog converter is used to perform the conversion.

The digital RS232 output is presented in decimal format in degrees, percent grade, or inch per foot rise. The output is formatted one reading per line for single axis units and two readings per line for dual axis units. The first reading for a dual axis unit represents channel 1 (typically side to side/roll) and the second reading represents channel 2 (typically front to back/pitch). The dual RDI can also be configured with both channels reading along the same axis for double redundancy.

There are up to four (4) Open Collector Switch Outputs that, if selected, can be factory set to switch at a predetermined angle anywhere within the selected measurement range. The switching function can be configured for either Normally Open for out of range indication or Normally Closed for in range indication. The outputs can be used to drive an external buzzer, horn, lamp, solenoid, or relay allowing for audible and/or visual warnings and equipment shut down control. Each switch output can be delayed from 0 to 16 seconds to eliminate false triggering. Available in both display and non-display models, with a display model the outputs are tied directly to the LED's on the front panel and are configured to indicate when switching occurs for the open collector switch outputs.

The RDI is powered by a 8-30VDC non-regulated power supply (default power), with optional 9V battery, 110VAC or 240VAC wall adapters, or cigarette lighter adaptor. Various connectors and cable options are available based on the application and operating environment.

Technical Data

INPUT PARAMETERS	
Measuring Angle Ranges	Standard: $\pm 10^\circ$, $\pm 30^\circ$, $\pm 70^\circ$ Scalable: Symmetrical $\pm 4^\circ$ min to $\pm 70^\circ$ max (single axis up to $\pm 100^\circ$) Scalable: Non-Symmetrical anywhere within full scale of range (ie: -10° to $+90^\circ$)
Measurement Axes	Single or Dual
Axis Mounting	Any Direction
Power Supply	8 to 30 VDC Non-Regulated, (5VDC Regulated optional)
Current Consumption	Display Version (Without LED): 15mA typical Display Version (One LED): 35mA typical Max All Options: 100mA max.

34 MOUNT PLEASANT ROAD • ASTON • PA • 19014 • USA

voice: 610-500-2000

fax: 610-500-2002

email: info@riekerinc.com

web: www.riekerinc.com



RIEKER
INCORPORATED

RDI Series: **RDR**

Digital Remote Inclinator Package

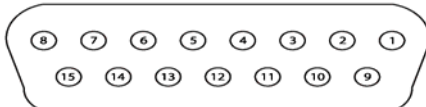
OUTPUT PARAMETERS			
Non-Linearity ¹	< 0.5% FR		
Null Repeatability	< 0.05°		
Transverse Sensitivity	<1.0% at 30° Tilt		
Response Time	< 0.3 seconds (300mSec), (slower response times available)		
Temperature Drift of Sensitivity ²	< -0.17%/°C for ±10° models and lower < -0.12%/°C for models greater than ±10°		
Temperature Drift of Zero ²	< ±0.05 mV/°C for ±10° models and lower < ±0.025 mV/°C for models greater than ±10°		
Temperature Compensation Output Drift	< ±1.0° (over full operating temperature range)		
Output Units	Degrees, (Percent Grade or Inch per Foot Rise optional)		
DISPLAY PARAMETERS			
LCD Display	Single Axis: Single Line Display, Dual Axis: Dual Line Display		
Display Resolution	Standard: 0.1°, (0.01° optional)		
Min / Max Readings	Stored in Volatile Memory		
Relative Zero	Stored in Volatile Memory		
Display LED's ³	1 Green, 1 Yellow, 1 Red (Activated per customer request)		
ANALOG VOLTAGE 0-5V OUTPUT			
Analog Voltage Output	2.25 ± 2.0 VDC		
Voltage Resolution	±10°	±30°	±70°
	<0.01°	<0.02°	<0.04°
DIGITAL SERIAL RS232 OUTPUT (DECIMAL OUTPUT)			
Baud Rate	9600		
Data Bits	8		
Parity	None		
Stop Bits	1		
OPEN COLLECTOR SWITCH OUTPUT			
Open Collector Outputs	Up to 4 available for activation		
Open Collector Current	1A each		
Switch Function	Normally Open: out of range indication, Normally Closed: in range indication		
Switch Trip Delay	0 to 16 seconds		
Switch Trip Angles	Factory set anywhere within range, (Adjustable Trip Setting optional)		
NOTES			
<ol style="list-style-type: none"> 1. Non-Linearity generated by best-fit straight line using least squares regression. Output is linear with respect to the input angle directly. 2. Sensor Temperature Drifts apply to Non-Temperature Compensated versions. 3. LED trip angles can only be set within the measuring range of the device and must match the open collector switch outputs if they are chosen. 			
DSUB-15 Wiring Connector for power and selected outputs	INTERFACE CONNECTOR 		
	<p>1. ANALOG 1A OUT = 0-5VDC 2. V IN = 12-30VDC 3. PS COMMON 4. ANALOG 2A OUT = NOT USED 5. SWITCH RETURN = N/A 6. SWITCH V IN = N/A 7. SWITCH 1 OUT = N/A 8. SWITCH 2 OUT = N/A 9. RS232 RXD = N/A or SWITCH 4 OUT** 10. RS232 TXD = N/A 11. RS232 COMMON = N/A 12. CHASSIS GND 13. ANALOG 1B = 0-10VDC or REMOTE SENSOR 1 INPUT 14. ANALOG 2B = N/A or REMOTE SENSOR 2 INPUT or EXTERNAL TEMPERATURE SENSOR 15. SWITCH 3 OUT = N/A</p> <p>Amp 745782-4 D-Sub Female - mates with Amp 747908-2 Male</p>		

The information and material presented may not be published, broadcast, rewritten, or redistributed without the express written consent of Rieker® Inc. ©2002-2007 Rieker® Inc. All Rights Reserved. FORM NUMBER RD0011_09/03 UPDATED: 01/07



RIEKER
INCORPORATED

RDI Series: **RDR** Digital Remote Inclinator Package

FIGURE 1: RDI Display Box, Dimensions (Inches [mm]) and Mounting Position

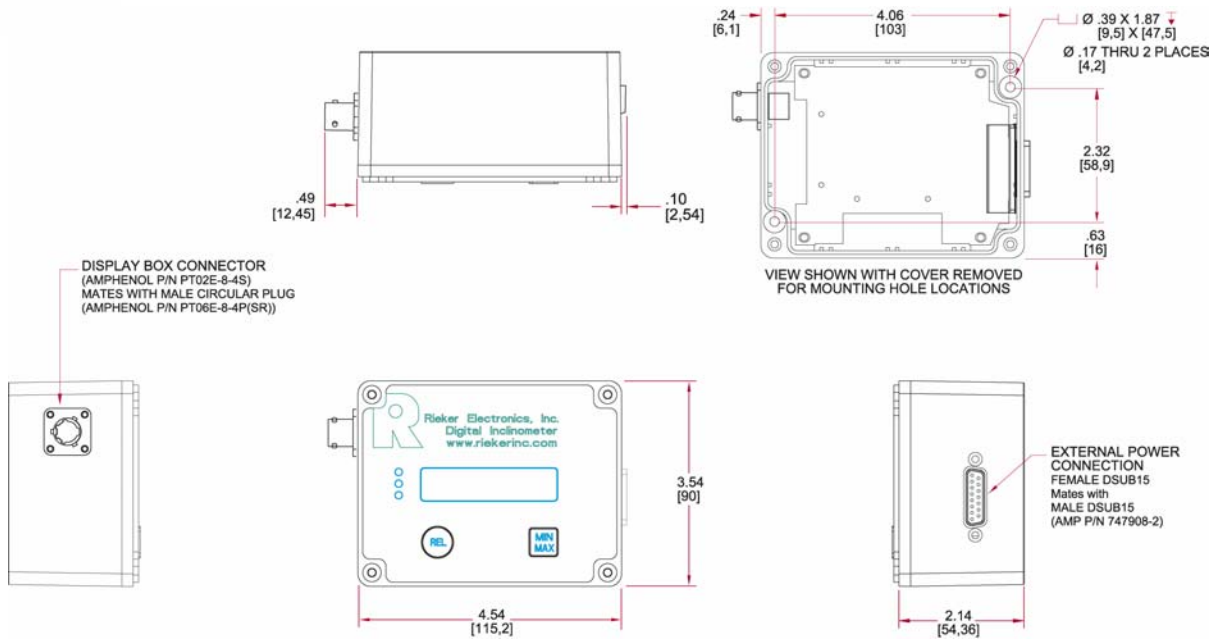
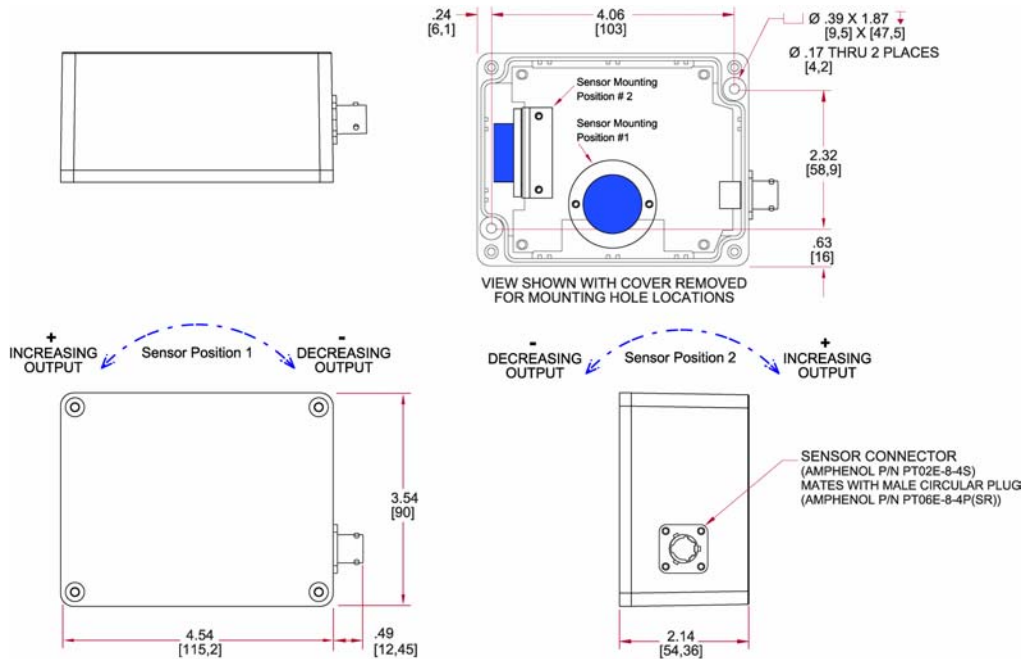

FIGURE 2: RDI Remote Inclinator Box, Dimensions (Inches [mm]) and Mounting Position



The information and material presented may not be published, broadcast, rewritten, or redistributed without the express written consent of Rieker® Inc. ©2002-2007 Rieker® Inc. All Rights Reserved. FORM NUMBER RD0011_09/03 UPDATED: 01/07



RIEKER
INCORPORATED

RDI Series: RDR

Digital Remote Inclinator Package

FIGURE 3: RDI Display Box with Mounting Feet, Dimensions (Inches [mm]) and Mounting Position

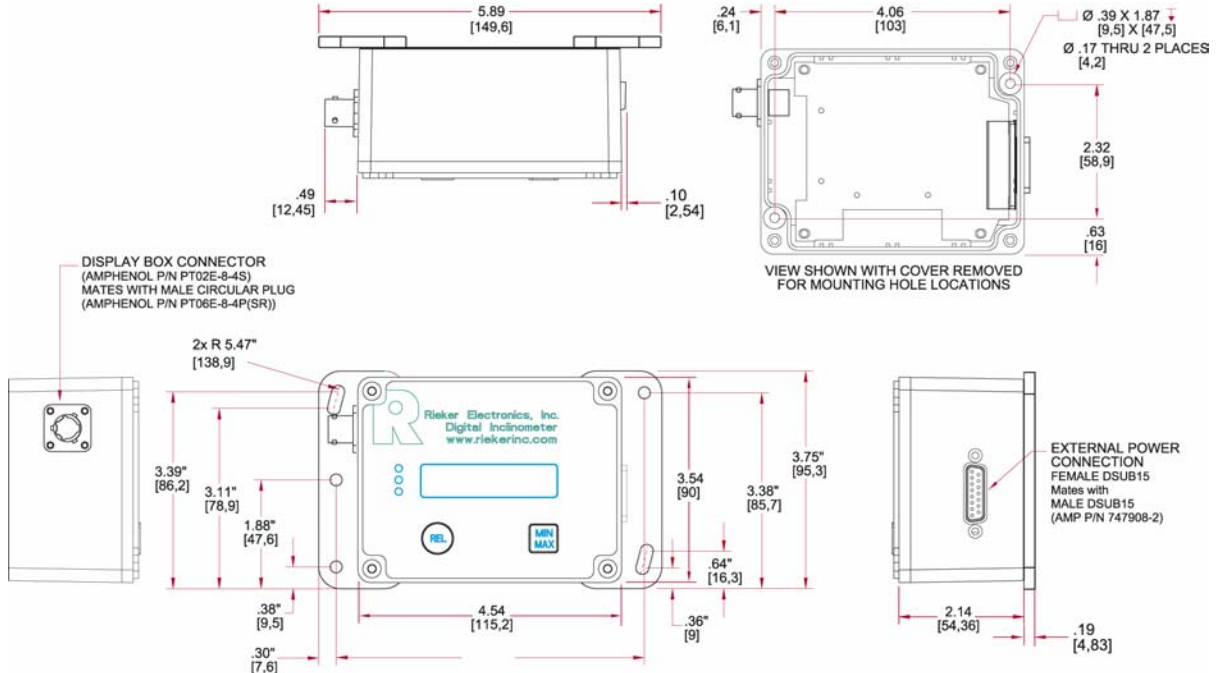
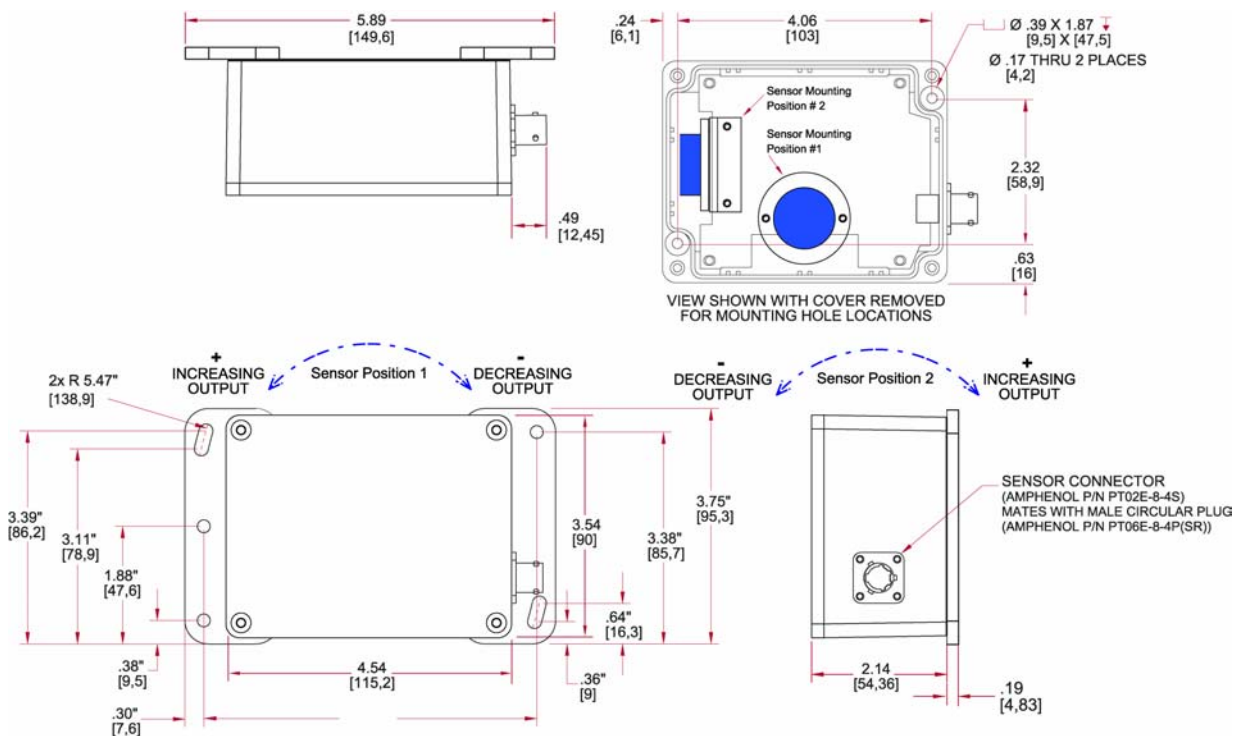

FIGURE 4: RDI Remote Inclinator Box (optional mounting feet), Dimensions (Inches [mm]) and Mounting Position



34 MOUNT PLEASANT ROAD • ASTON • PA • 19014 • USA

voice: 610-500-2000

fax: 610-500-2002

email: info@riekerinc.com

web: www.riekerinc.com

The information and material presented may not be published, broadcast, rewritten, or redistributed without the express written consent of Rieker Inc. ©2002-2007 Rieker Inc. All Rights Reserved. FORM NUMBER RD0011_09/03 UPDATED: 01/07