

## Liquid Capacitive Inclinometer Sensor with Full 0° to 360° measurement range.



### Description

The NG360 is a liquid capacitive based inclinometer used for measuring the tilt angle of any object with respect to gravity within a 0 to 360° range. This inclinometer features an integrated 16-bit single chip microprocessor, which provides for linearity and temperature compensation. The basic sensor consists of four separate sensing elements whose outputs are combined to provide a highly accurate linear output over a complete 360° tilt range. An inclusive EEPROM stores the calibration data and dynamic control functions. The embedded software virtually eliminates total errors by compensating temperature drifts and sets the sensor dynamics for specific customer applications. It provides a very accurate 360° angle output with a RS485 interface. When used along with the SC485B (RS232/RS485) converter the user has the possibility of connecting up to 78 units on the same communication line.

Two computer programs are included along with the NG360, "Get Angle" and "NG360 Setup", for viewing the measured angle real time. These programs run on Intel compatible PC's under MS Windows 95/98. Although the NG360 can be operated on any half duplex RS485 interface, we recommend the Rieker Electronics interface converter SC485B for problem free operation.

### Applications

The NG360 inclinometer is suitable for applications requiring the measurement of any angle for further processing on a PC.

Typical areas of application include construction, mining, vehicles, aircraft, ships, surveying equipment, and transportation and conveyor systems.

### Features

- *RS485 Output - Bus and Multi-Sensor Capable*
- *Integrated 16 Bit Microprocessor*
- *EEPROM Storage of Sensor Parameters*
- *Windows Based Software Supporting Bi-Directional Calibration*
- *Full 360° Angle Sensing*
- *0.01° Resolution*
- *Linearity and Temperature Compensated*
- *Insensitive to electromagnetic fields*
- *Adjustable zero-position with 360° locking ring*
- *-40°C to +85°C Operating Temperature Range*
- *IP65 Protection*
- *Vibration and Shock Resistant*



**RIEKER**  
INCORPORATED

**NG360**

**General Specifications Brochure**

TECHNICAL SPECIFICATIONS	
MEASURING RANGE	360°
RESOLUTION	0.01°
MAX. NON-LINEARITY	±0.25°
TRANSVERSE SENSITIVITY	<1% at 45° cross angle
OUTPUT RESPONSE TME	< 0.3 Sec. (<300mSec)
SUPPLY VOLTAGE "ON" DELAY TIME	< 50mSec
POWER SUPPLY	9V ... 15V
CURRENT CONSUMPTION	approx. 40mA
MECHANICAL CHARACTERISTICS	
HOUSING	30% Glass Filled PBT Plastic
ENVIRONMENTAL PROTECTION	IP65
MOUNTING	Flat Vertical Surface with Supplied Mounting Ring
OUTLINE DIMENSIONS	Ø 1.92" (Ø 48.8mm) X 0.85" (21.6mm) h
	With Mounting Ring: Ø 2.64" (Ø 67mm) X .85" (21.6mm) h
ELECTRICAL CONNECTION	Ø 0.182" (Ø 4.6mm) Shielded Cable x 1.65' (0.5m) pigtail leads
WEIGHT	Approx. 3.88 ounces (110 grams) (not including mounting ring)
OPERATING TEMPERATURE	-40°F to +185°F (-40° to +85°C )
STORAGE TEMPERATURE	-49°F to +194°F (-45° to +90°C )

**Figure 1: Dimensions and Mounting Position (inches [mm])**

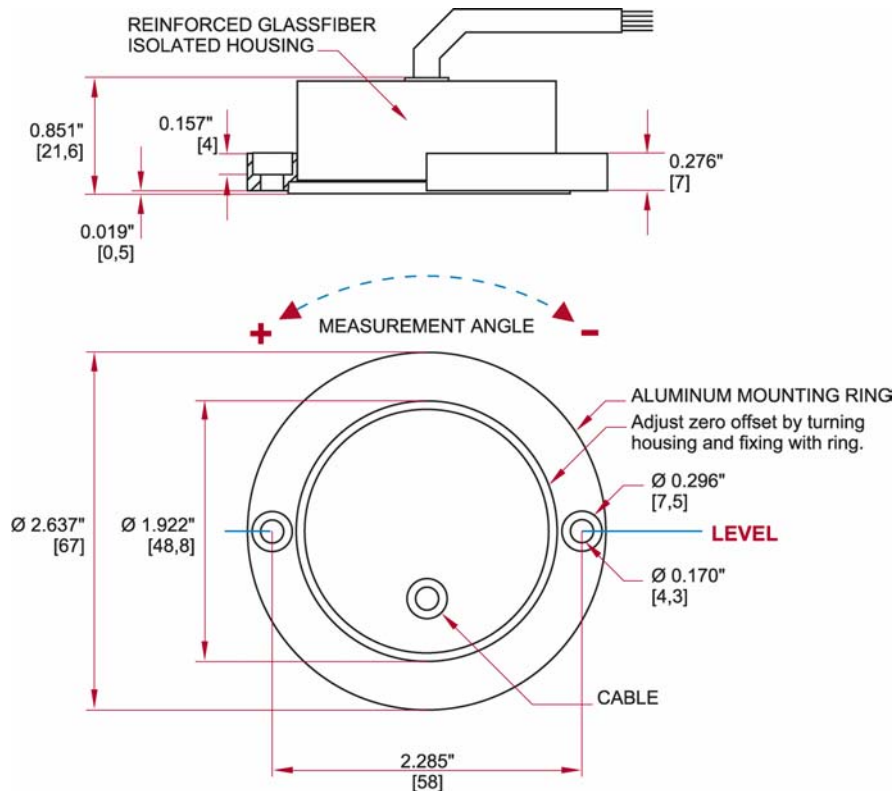

34 MOUNT PLEASANT ROAD • ASTON • PA • 19014 • USA

voice: 610-500-2000

fax: 610-500-2002

email: info@riekerinc.com

web: www.riekerinc.com

The information and material presented may not be published, broadcast, rewritten, or redistributed without the expressed written consent of Rieker® Inc. ©2002-2007 Rieker® Inc. All Rights Reserved. FORM NUMBER SK0015\_07/02 UPDATED: 02/07

**Figure 2:** Connection to RS232/RS485 converter (p/n SC485B)

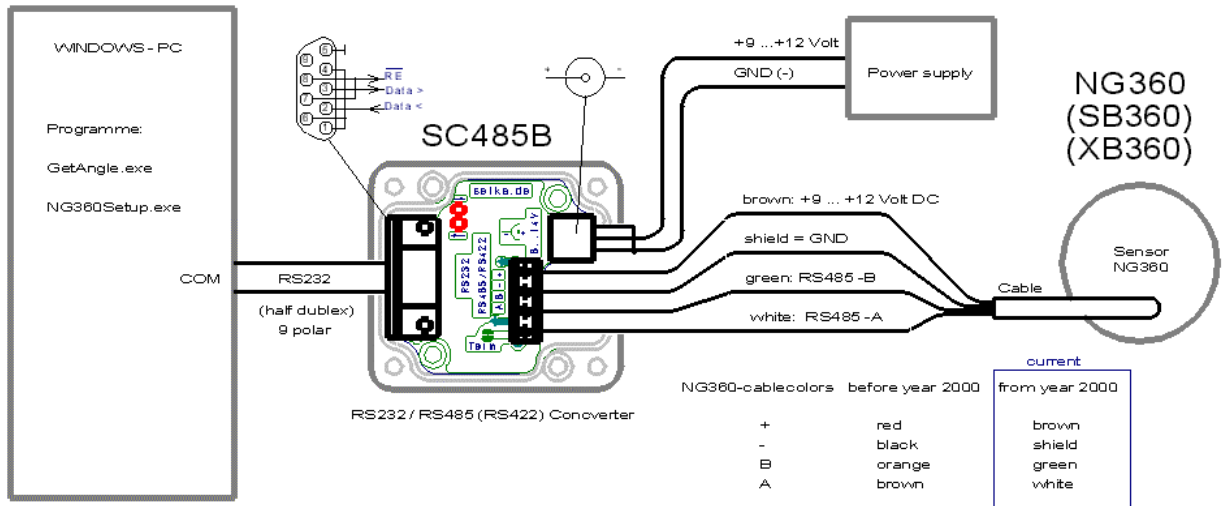

**Figure 3:** NG360 Sensor Connection to RS485 Bus

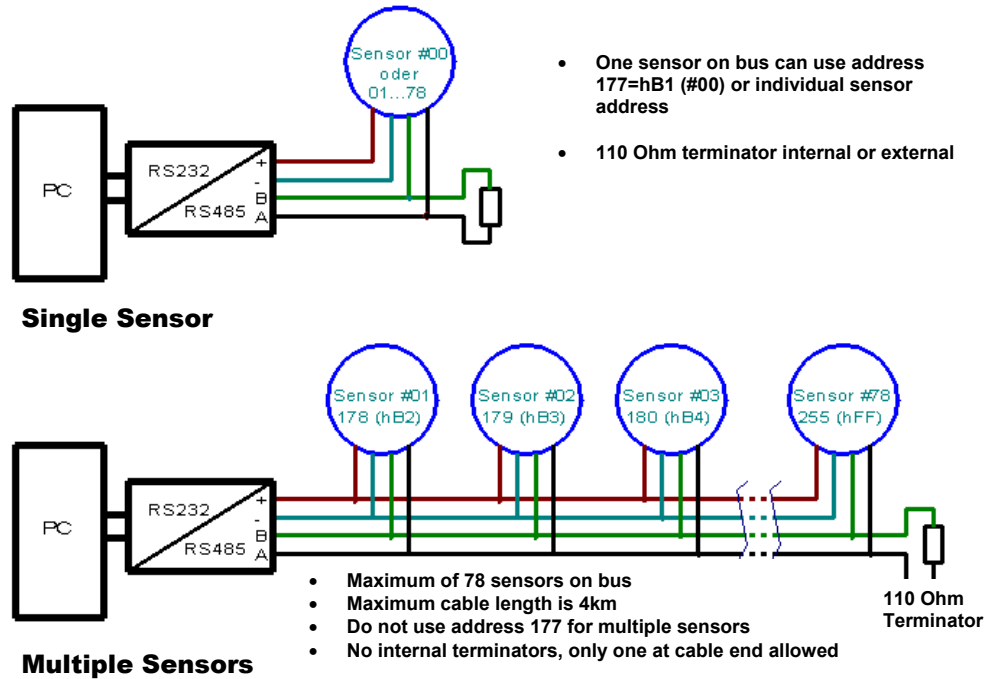

PC COM PORT TO RS232 / RS485 PROTOCOL	
BAUD RATE (BIT/SEC)	9600
DATA BITS	8
PARITY	None
STOP BIT	1
PROTOCOL	None



NG360 DATA PROTOCOL			
STEP	PC TRANSMIT	SENSOR TRANSMIT	NOTES
1.	Address (e.g. B1, B2 or B3...)		
2.	ENQ (05h)		
3.	15ms Pause (switching from transmit to receive in sensor)		
4.		STX (02h) 359,99 Angle in ASCII code ETB (17h)	
5.		Check Sum (2 Byte ASCII code) \$(24h)	The check sum is a byte by byte XOR concatenation of the sensor value measured in step 4 (Ex.: 02h XOR 359.99 XOR 17h)
6.	15ms Pause (Switching from receive to transmit in sensor)		
7.	ACK (06h) When check sum is OK NAK (15h) When check sum fails		
8.		If ACK, then finish If NAK, return to 3	
INSTALLATION AND MOUNTING INSTRUCTIONS ( Interfacing NG360 with the SC485B Adapter)			
STEP	HARDWARE PREPARATION		
1.	The NG360 inclinometer will need to be mounted on a vertical mounting plane. The SC485B (RS232/RS485) adapter can be mounted on either a horizontal or vertical mounting plane.		
2.	To mount the NG360, prepare a vertical surface with two tapped holes 2.283" apart for the supplied M4 mounting screws. Refer to Figure 1 for the NG360 outline dimensions.		
3.	To mount the SC485B adapter, prepare the mounting surface with two tapped holes, tap for either M4 or #8-32 screws. (Screws are not supplied.) Refer to Figure 2 for mounting hole locations. Note all dimensions are in millimeters.		
4.	Mount the NG360 to the mounting surface using the supplied mounting ring and M4 mounting screws. Ensure the unit is oriented so that the writing on the label appears horizontal and upright when looking at it straight on. This is the approximate zero position. To zero the unit, loosen the two mounting screws and rotate the sensor within its ring until the output reads zero. Tighten screws when satisfied.		
5.	Remove the 4 screws from the SC485B adapter lid to lift the cover.		
6.	Route the NG360 cable through the SC485B adapter port and connect the wires as shown in Figure 3. Refer to Figure 4 for the NG360 and RS485 Bus diagram.		
7.	Mount the SC485B adapter with two M4 or #8-32 screws. Replace cover.		
8.	Connect the 12VDC adapter plug to the SC485B adapter and the other end to 110VAC wall receptacle.		
9.	Connect a 9-pin D-Sub male connector and cable to the PC com port.		
STEP	SOFTWARE PREPARATION		
<b>Software (WINDOWS 98, WINDOWS XP)</b>			
To display the measurement results and configure the sensor the following programs are used. These programs require a PC running Windows 95/98 or Windows XP. Although the NG360 will operate from any half-duplex RS485 port, we recommend using the SEIKA interface converter SC485B. NG360 programs should be copied to the hard drive before running them!			
1.	Load the enclosed software NG360Setup.exe and GetAngle.exe onto a PC.		
<b>NG360Setup.exe:</b> This program can be used to change several parameters of the NG360. These parameters can be read, modified and then saved permanently in the NG360 EEPROM. This does not affect any calibration values.			

34 MOUNT PLEASANT ROAD • ASTON • PA • 19014 • USA

voice: 610-500-2000

fax: 610-500-2002

email: info@riekerinc.com

web: www.riekerinc.com

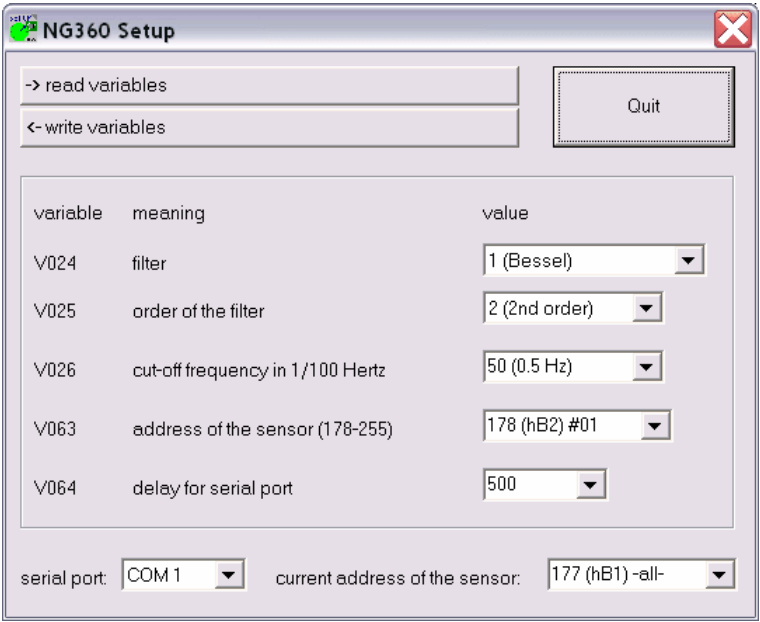
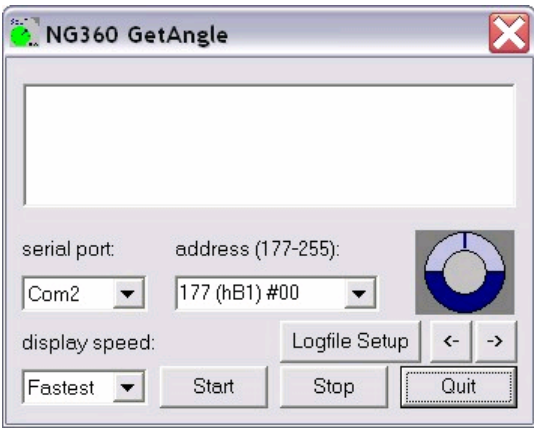
2.	Run the executable file, NG360Setup.exe to setup system parameters. Parameters that can be reconfigured are data filtering with regards to filter type (Bessel, Period, Butterworth, or Tschebychev), filter order (either no filter, first, or second order), and filter frequency (0.1Hz, 0.5Hz, and 1Hz). The sensor address can also be set and changed if more than one sensor is connected. Refer to Figure 3 for connecting multiple sensors. PC COM port assignment is also accomplished with this program.																		
3.	<p>The following screen should appear when NG360Setup.exe is executed. The PC COM port shows in the bottom left hand corner and the current sensor address in the bottom right hand corner. If only one sensor is connected, the default address of 177 (hB1) #00 will enable the software to output sensor angles. If multiple units are connected, address 177 (hB1) cannot be used!!! The reason being that all sensors are programmed to respond to the base address of 177 (hB1), in the event of multiple units, a bus conflict would result. Each individual sensor on the bus will need to have a unique address.</p>  <p>The screenshot shows the 'NG360 Setup' dialog box with the following settings:</p> <table border="1"> <thead> <tr> <th>variable</th> <th>meaning</th> <th>value</th> </tr> </thead> <tbody> <tr> <td>V024</td> <td>filter</td> <td>1 (Bessel)</td> </tr> <tr> <td>V025</td> <td>order of the filter</td> <td>2 (2nd order)</td> </tr> <tr> <td>V026</td> <td>cut-off frequency in 1/100 Hertz</td> <td>50 (0.5 Hz)</td> </tr> <tr> <td>V063</td> <td>address of the sensor (178-255)</td> <td>178 (hB2) #01</td> </tr> <tr> <td>V064</td> <td>delay for serial port</td> <td>500</td> </tr> </tbody> </table> <p>serial port: COM 1      current address of the sensor: 177 (hB1) -all-</p>	variable	meaning	value	V024	filter	1 (Bessel)	V025	order of the filter	2 (2nd order)	V026	cut-off frequency in 1/100 Hertz	50 (0.5 Hz)	V063	address of the sensor (178-255)	178 (hB2) #01	V064	delay for serial port	500
variable	meaning	value																	
V024	filter	1 (Bessel)																	
V025	order of the filter	2 (2nd order)																	
V026	cut-off frequency in 1/100 Hertz	50 (0.5 Hz)																	
V063	address of the sensor (178-255)	178 (hB2) #01																	
V064	delay for serial port	500																	
4.	Once a sensor address is selected, the corresponding sensor can be probed for its current parameter settings. Click on "read variables". This will read the current filter settings and sensor address and display them in the appropriate fields. The variables can be modified by selecting on the drop down menus and then permanently written to the EEPROM memory by clicking on "write variables". The variable V064 "delay for serial port" determines the time delay between the individual data bytes transmitted by the sensor. This value can be increased for slower PC interfaces for safer data communication. Default value is 500.																		
<p><b>GetAngle.exe:</b> This program displays the angle of one or more NG360, which are connected through a RS232/RS485-Converter (i.e. p/n SC485B) to the PC. The serial port COM, the sensor address and the display speed (averaging of several measurements) can be adjusted. Additionally, measurements can be saved to a logfile in regular time-intervals, for further processing i.e. with MS Excel.</p>																			
5.	<p>Now run the executable file, GetAngle.exe. This program displays the measured angle for each sensor queried on the RS485 Bus. The following screen should appear.</p>  <p>The screenshot shows the 'NG360 GetAngle' dialog box with the following settings:</p> <p>serial port: Com2      address (177-255): 177 (hB1) #00</p> <p>display speed: Fastest      Logfile Setup      Start      Stop      Quit</p>																		
6.	Set the correct Com port and address. Note address 177 (hB1) #00 can only be used when one sensor is connected. Clicking on Start will show the sensor output real time. If you want to change the filter parameters go back to the setup program.																		

The information and material presented may not be published, broadcast, rewritten, or redistributed without the expressed written consent of Rieker® Inc. ©2002-2007 Rieker® Inc. All Rights Reserved. FORM NUMBER SK0015\_07/02 UPDATED: 02/07



**RIEKER**  
INCORPORATED

**NG360Scan.exe:** Use this program to identify every NG360 sensor connected to a serial PC COM port through a RS232/RS485-Converter. The program scans the whole range of possible NG360 addresses and displays the angle values send by each connected sensor.

7.

Program NG360Scan.exe is also supplied on the disk. This program will determine which sensors are active on the bus and then allow continuous reading of multiple sensors. The following screen will appear when executed.

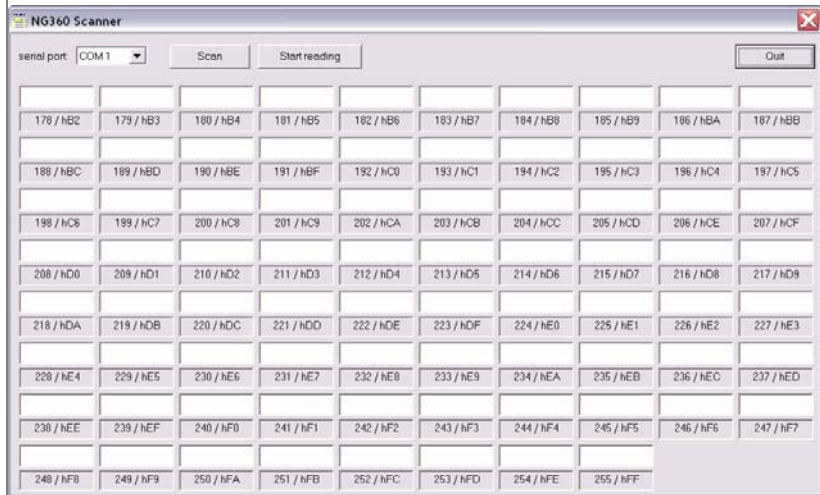

8.

Select the Com port and click on Scan. The program transmits an inquiry to all 78 possible NG360 addresses and waits for a response. If a sensor answers, the received measured angle is displayed over that sensors address. Click on Start reading to obtain continuous angle measurements from the active sensors. Press Stop reading when finished.

**NG360Example.exe:** This directory contains an example program for programmers, with complete MS Visual C++ sourcecode. This open source example program developed using MS Visual C++ 5.0 provides some information how to develop interface software for the RS232/RS485 converter and the NG360 sensors.

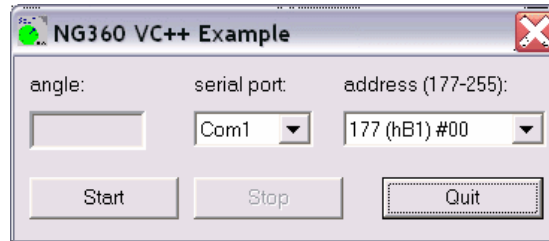

### HARDWARE RESET

The NG360 sensor is RESET automatically at power on by a defined sequence of operations. The timing for the power on sequence is important for the correct function of the internal microcomputer. The starting edge of the supply voltage should be as short as possible for correct operation.

A supply voltage with a slow rise time or one that bounces can lead to the internal microcomputer program to crash. If this occurs, the sensor will give the impression that it is defective and no longer working. This can normally be fixed by shutting the power off and restarting the process over again making sure the proper input conditions are met. Similar problems can occur if the operating voltage drops below 9V. With the correct input voltage the actual sensor life is unlimited.