

### Formidable Protection Against Extreme & Underwater Environments, Aggressive Media, and Seawater - a Heavy-Duty Sensor Package.



Photo above shows XB with PG9 Connector.

Photo to left shows XB with SubConn Underwater Quick Disconnect Connector.

#### Description

The XB is a pressure, seawater, and corrosion resistant stainless steel sensor enclosure that is perfect for extreme environment protection and underwater use.

Available as a single or dual inclinometer package, the XB offers a housing option to the SB Aluminum housing sensor packages. Sensor specifications and outputs are exactly the same as with the SB sensor packages.

Power input and sensor output would be provided by a cable (optional) that attaches via a liquid tight cable grip fitting (PG9 VA) or an underwater quick disconnect patch cord. The SubConn Underwater connector adds flexibility to the sealed environment.

#### Applications

The XB can be used in any extremely rough environment where exact inclination or acceleration measurements must be obtained in aggressive media or below sea level under pressure load.

Typically used for platform leveling or boom angle monitoring of off shore drilling platforms, construction and mining equipment, as well as sea going vessels. It is particularly suited for offshore applications where the use of an underwater patch cord allows sensor connection underwater.

#### Features

- *Heavy-duty stainless steel housing alternative to the Aluminum SB housing*
- *Inclination or acceleration*
- *Single or dual axis*
- *0-5V or 4-20mA outputs*
- *up to  $\pm 80^\circ$  measuring range*
- *Seawater resistant - rated V4A*
- *Pressure resistant - 10 bar (1Mpa), 100m WG*
- *Corrosion resistant*
- *Rigid 4 point attachment of 3.2mm base circuit board*
- *Sensor and sensor electronics are galvanically isolated from housing*

TECHNICAL DATA		
TERMINAL CONNECTION	Maximum: 2 x 1.5 mm <sup>2</sup> (2 x 16 AWG)	
RANGE, RESOLUTION, OUTPUT	According to sensor used	
SENSING POSITION	Arbitrary	
INCLINATION PLANE	SB1, SB2 (N)	3 main Housing Directions
	SB1, (NG)	Parallel to the Housing Bottom
ACCELERATION PLANE	SB1, SB2 (B, BD, BDK)	X, Y, Z-coordinates of Housing
ELECTRICAL VALUES	According to the Appropriate SB Sensor Box Requirements	
MECHANICAL CHARACTERISTICS		
HOUSING	Stainless Steel V4A (seawater resistant)	
PRESSURE STRENGTH	10 bar (1Mpa), 100 meters below sea level	
ENVIRONMENTAL PROTECTION	IP68	
MOUNTING	Flat Vertical or Horizontal Surface (specified at time of order)	
INPUT/OUTPUT CONNECTION	Cable Entry	PG9 (V4A steel with integrated strain relief, handles 8-10mm cable diameter)
	Patch Cord	SubConn® Underwater Plug Connector
WEIGHT	4 lbs (1,82 kilograms) (not including cable)	
OPERATING TEMPERATURE	-40°F to +185°F (-40° to +85°C)	
STORAGE TEMPERATURE	-49°F to +194°F (-45° to +90°C)	

**Figure 1:** Dimensions and Mounting Position (inches [mm])

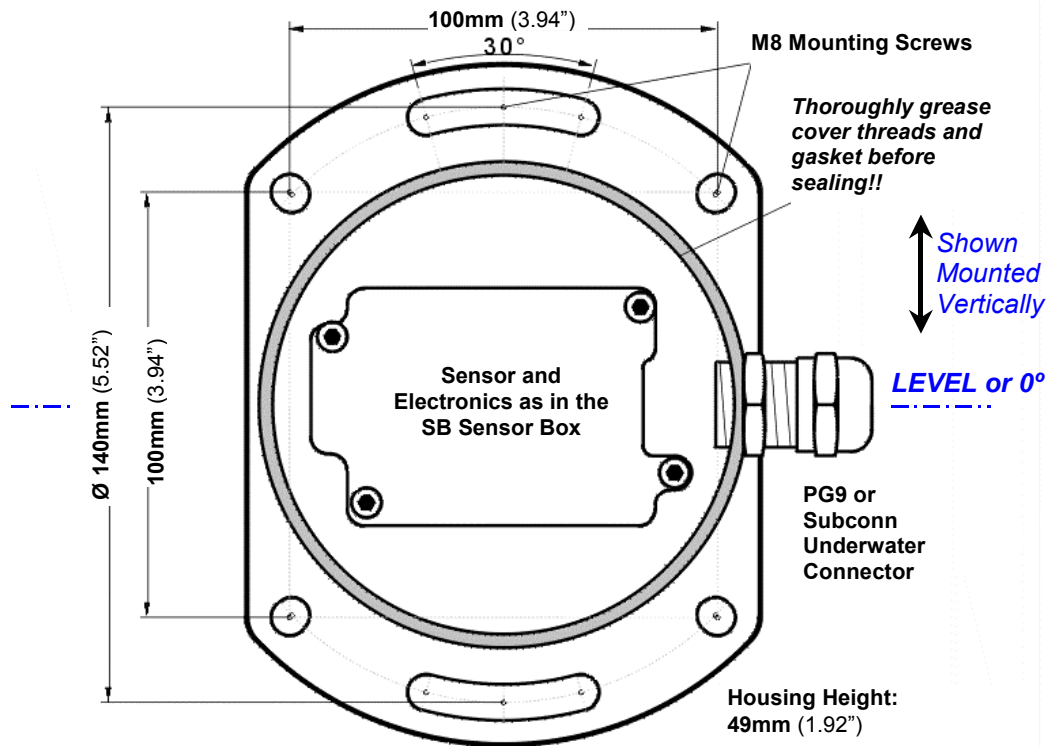

The information and material presented may not be published, broadcast, rewritten, or redistributed without the expressed written consent of Rieker® Inc.  
 The content presented is provided for informational purposes only and subject to change.  
 ©2002-2007 Rieker® Inc. All Rights Reserved.  
 FORM NUMBER: SK0010\_10/02 UPDATED: 01/07