

Rugged ALL-weather Inclinometer Providing Analog Voltage (0...5VDC) or Digital Serial (RS232) Output.



Description

The H4 Series of inclinometers provide single axis inclination sensing in a rugged environmentally protected metal housing. The sensing package incorporates a liquid capacitive sensing element and integrated temperature compensation over the industrial operating range of -40° to +85°C.

These sensors are available with a choice of two output configurations, analog voltage or digital serial outputs. These outputs are linear with respect to the input angle directly.

Digital Serial (RS232) Output

The Serial output (RS232) transmits the degree of angle in a decimal format. This output provides a continuous stream of readings - one reading per line at approximately 250msec per reading. The H4 transmits the output to a computer through its serial port, using HyperTerminal as the interface. The unit is configured for 9600 baud, 8 data bits, no parity, 1 stop bit.

Features

- Single Axis Angle Measurement
- 3 Ranges: ±30°, ±45°, ±70°
- Temperature Compensated
- Analog Voltage 0...5V Output
- Serial Digital RS232 Output
- Vibration and shock resistant
- Environmentally sealed to IP67
- Rugged die-cast Zinc housing
- EMC protected
- Mechanical Zero adjustment
- Common footprint for easy field install

Applications

- Platform Leveling
- Vehicle Tilt Monitoring
- Antenna Positioning
- Boom Angle Indicating
- Process Machinery

The information and material presented may not be published, broadcast, rewritten, or redistributed without the expressed written consent of Rieker® Inc.
 The content presented is provided for informational purposes only and subject to change.
 ©2014 Rieker® All Rights Reserved.
 FORM NUMBER: H40001_02/05 UPDATED: 7/25/14



H4 Series

General Information Brochure

Technical Specifications

INPUT PARAMETERS	
MEASURING RANGES	$\pm 30^\circ$, $\pm 45^\circ$, $\pm 70^\circ$
MEASUREMENT AXIS	Single
POWER SUPPLY	8...30 VDC Non-Regulated optional 5VDC Regulated
OUTPUT PARAMETERS	
NON-LINEARITY ¹	< 0.5% Full Range for $\pm 30^\circ$ model < 0.2% Full Range for $\pm 45^\circ$, $\pm 70^\circ$ models
NULL REPEATABILITY	< 0.05°
TRANSVERSE SENSITIVITY	< 1.0% at 30° Tilt
SENSOR ELEMENT RESPONSE TIME	< 0.3 seconds (<300mSec)
BANDWIDTH	3 Hz
OPTIONAL TEMPERATURE COMPENSATION OUTPUT DRIFT	< $\pm 1.0^\circ$ (over full operating temperature range)
TEMPERATURE RANGE	
OPERATING TEMPERATURE	-40°F to +185°F (-40°C to +85°C)
STORAGE TEMPERATURE	-49°F to +194°F (-45°C to +90°C)

ANALOG (0...5V) OUTPUT		Temperature Compensation
		Over full operating temperature range
ZERO OFFSET		2.5VDC typical
ANALOG VOLTAGE OUTPUT (Linear Range)		0.5...4.5VDC
OUTPUT VOLTAGE SENSITIVITY		
	$\pm 30^\circ$	66.7mV/°
	$\pm 45^\circ$	44.4mV/°
	$\pm 70^\circ$	28.6mV/°
ACCURACY OVER TEMPERATURE		
	$\pm 30^\circ$	< $\pm 0.5^\circ$
	$\pm 45^\circ$	< $\pm 0.5^\circ$
	$\pm 70^\circ$	< $\pm 1.0^\circ$
RESOLUTION		
	$\pm 30^\circ$	< 0.02°
	$\pm 45^\circ$	< 0.03°
	$\pm 70^\circ$	< 0.04°
CURRENT CONSUMPTION		10mA typical
OUTPUT IMPEDANCE		< 100 OHMS
DIGITAL (RS232) OUTPUT		Temperature Compensation
		Over full operating temperature range
	$\pm 30^\circ$	< $\pm 0.5^\circ$
	$\pm 45^\circ$	< $\pm 0.5^\circ$
	$\pm 70^\circ$	< $\pm 1.0^\circ$
CURRENT CONSUMPTION		10mA typical
RS232 OUTPUT FORMAT		ASCII Decimal
	BAUD RATE	9600
	DATA BITS	8
	PARITY	None
	STOP BITS	1
TRANSMISSION RATE		Continuously updated every 25mSEC

The information and material presented may not be published, broadcast, rewritten, or redistributed without the expressed written consent of Rieker® Inc.
 The content presented is provided for informational purposes only and subject to change.
 ©2014 Rieker® All Rights Reserved.
 FORM NUMBER: H40001_02/05 UPDATED: 7/25/14

MECHANICAL CHARACTERISTICS	
HOUSING	Die Cast Zinc
ENVIRONMENTAL RATING	IP67
MOUNTING HOLES	Two #6-32
MOUNTING PLANE	Vertical Surface
OUTLINE DIMENSIONS	Ø1.95" x 1.1" (Ø49.5 x 28mm) See Drawing
ELECTRICAL CONNECTION	1ft. Teflon Cable with 3 pigtail leads
WEIGHT	8 ounces (227 grams)
Notes: 1. Non-linearity generated by best fit straight line using least squares regression. Output is linear with respect to the input angle directly.	

Figure 1: Dimensions (inches [mm]) and Wiring Connections

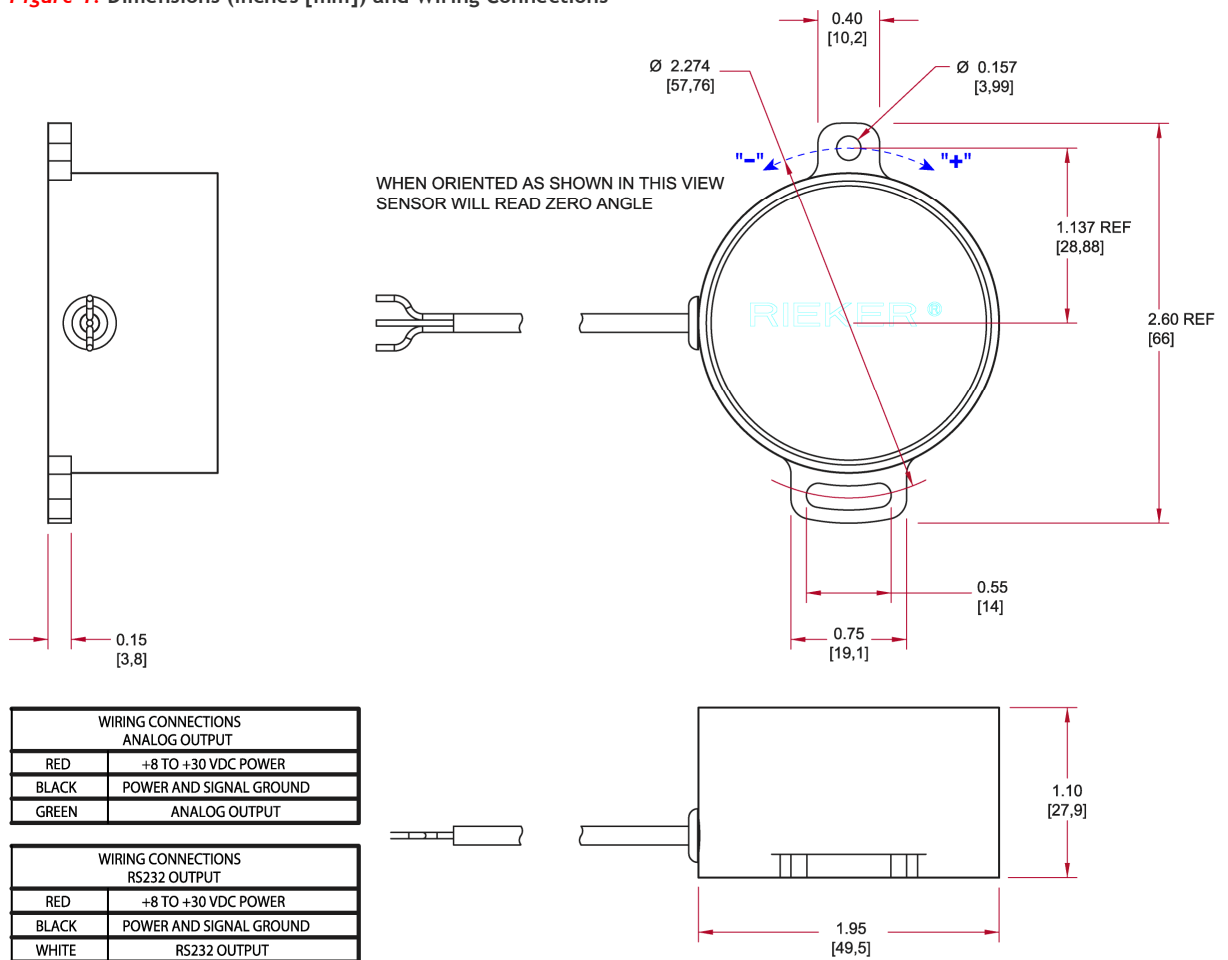

The information and material presented may not be published, broadcast, rewritten, or redistributed without the expressed written consent of Rieker® Inc.
 The content presented is provided for informational purposes only and subject to change.
 ©2014 Rieker® All Rights Reserved.
 FORM NUMBER: H40001_02/05 UPDATED: 7/25/14



H4 Series

General Information Brochure

TABLE 1: Part Number for Ordering Information

PART NUMBER MATRIX CHART	
	H 4 A 1 - 30 - -
	OPTION CODE
HOUSING	
MACHINED ZINC METAL (Default)	4
ALTERNATIVE HOUSING	N/A
OUTPUT	
ANALOG	A
DIGITAL SERIAL (RS232)	S
TEMPERATURE COMPENSATION	
LEVEL 1	1
ANGLE RANGES	
"XX" = $\pm 30^\circ$, $\pm 45^\circ$, $\pm 70^\circ$	"XX"
SPECIAL SCALING	N/A
INPUT POWER	
8 TO 30VDC (Default)	BLANK
5VDC	V
MODEL NUMBER	
STANDARD (or stock) CONFIGURATION (Default)	BLANK
CUSTOM SPECIAL: "-X" = LETTER ASSIGNED AT TIME OF ORDER	"-X"

As shown above the part number H4A1-30 represents a single axis unit with a $\pm 30^\circ$ measuring range, Analog output, Level 1 Temperature Compensation, 8 to 30VDC supply power.

The information and material presented may not be published, broadcast, rewritten, or redistributed without the expressed written consent of Rieker® Inc.
 The content presented is provided for informational purposes only and subject to change.
 ©2014 Rieker® All Rights Reserved.
 FORM NUMBER: H40001_02/05 UPDATED: 7/25/14